

**PROPRIETARY AND CONFIDENTIAL**

THE INFORMATION CONTAINED IN THIS DRAWING IS THE SOLE PROPERTY OF CAPSTAN AG INC. ANY REPRODUCTION IN PART OR AS A WHOLE WITHOUT WRITTEN PERMISSION OF CAPSTAN AG INC IS PROHIBITED

REV	ECR	DESCRIPTION	DATE	BY
F		Redrawn in SolidWorks, Added Dims for Slots and Holes 1) Slots were Holes	9/7/12	BLS
G	2019	Finish, Charcol Gray Powder over Zinc was Powder Coat, w/Zinc option	3/31/16	BLS

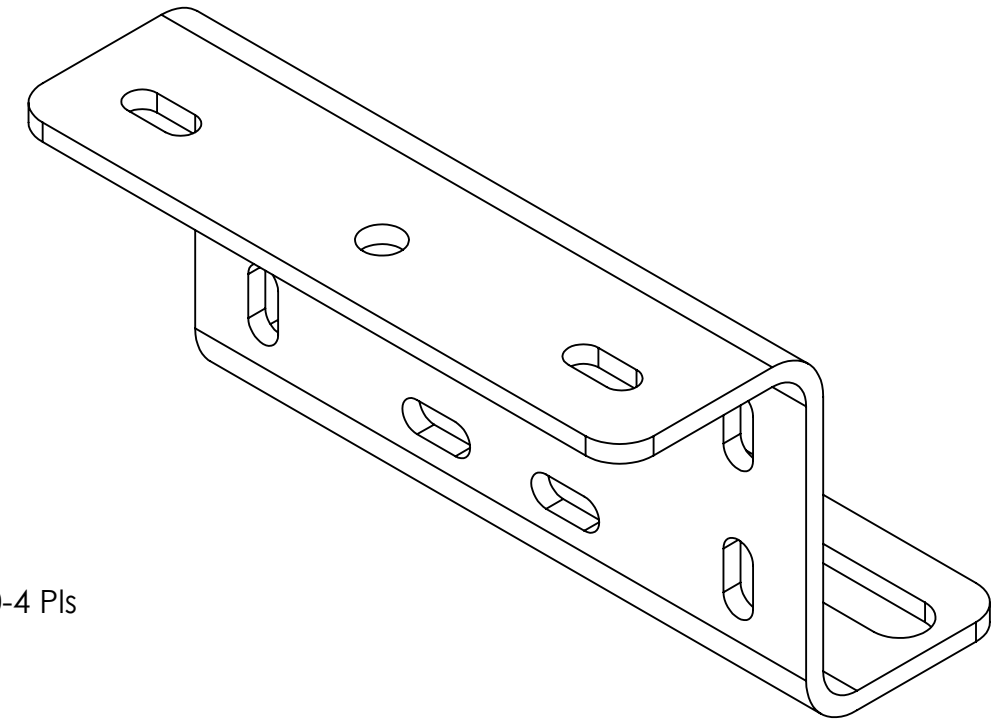
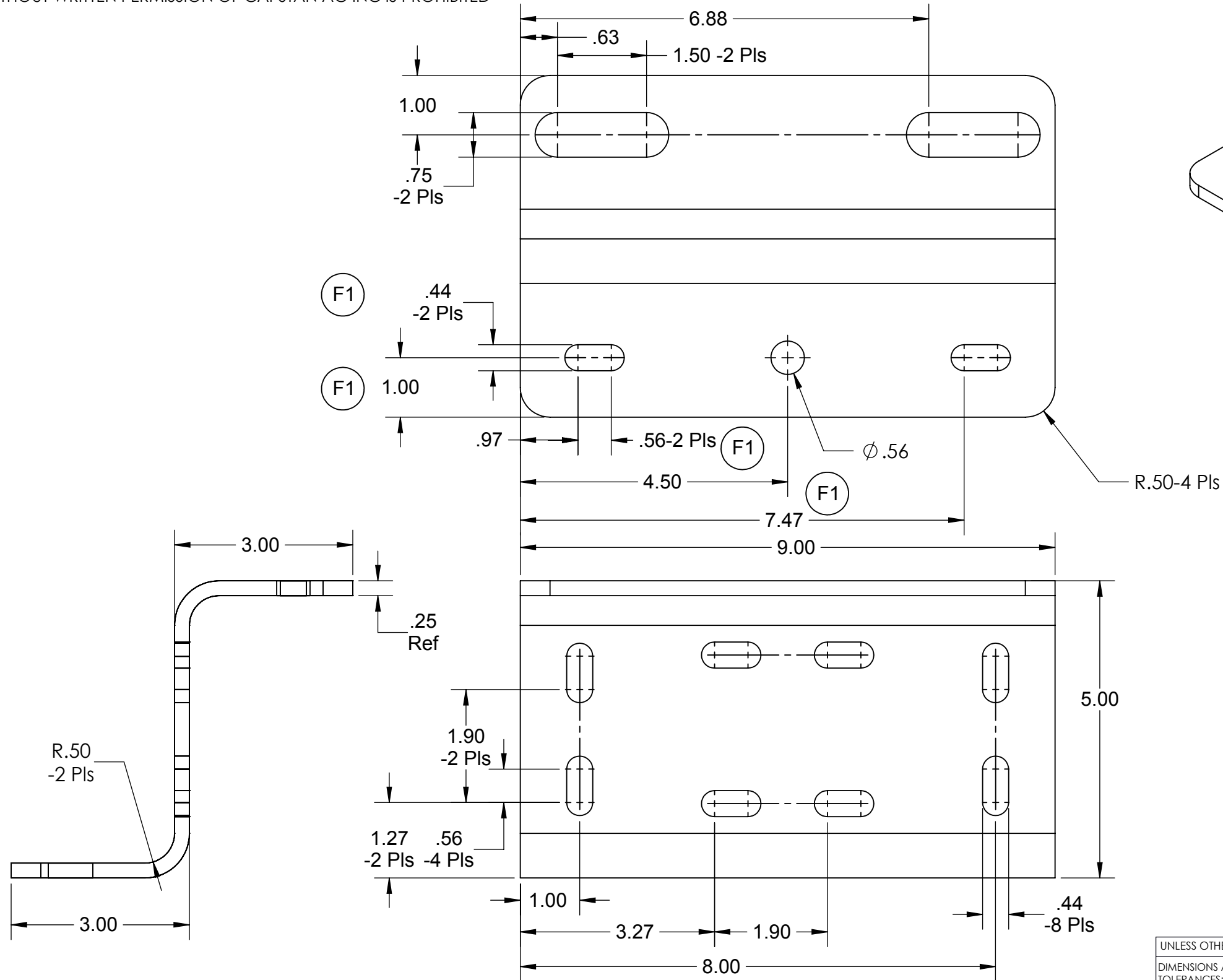

Notes:

- 1. Optional Material: 1/4", 304 Stainless Steel.
- 2. Finish: Powder coat Gray over Zinc plate.

UNLESS OTHERWISE SPECIFIED:				<b>CAPSTAN AG SYSTEMS, INC.</b> 101 N. KANSAS AVE., TOPEKA, KS 66603	
DIMENSIONS ARE IN INCHES TOLERANCES: FRACTIONAL ± ANGULAR: MACH ± BEND ± TWO PLACE DECIMAL ± THREE PLACE DECIMAL ± INTERPRET GEOMETRIC TOLERANCING PER:		Name Drawn <b>RDC</b> Checked QA APP	Date 8/5/03	TITLE: <b>Mounting Bracket Enclosure, Plated</b>	
MATERIAL <b>1/4" HRS</b> FINISH	SIZE <b>B</b>	DWG No: <b>620135-001</b>	REV <b>G</b>	SCALE: <b>None</b>	
DO NOT SCALE DRAWING				SHEET 1 of 1	