

PROPRIETARY AND CONFIDENTIAL

THE INFORMATION CONTAINED IN THIS DRAWING IS THE SOLE PROPERTY OF CAPSTAN AG INC. ANY REPRODUCTION IN PART OR AS A WHOLE WITHOUT WRITTEN PERMISSION OF CAPSTAN AG INC IS PROHIBITED

Rev	ECR	Description	Date	By	App
A	2076	Production Release	11/30/16	BLS	

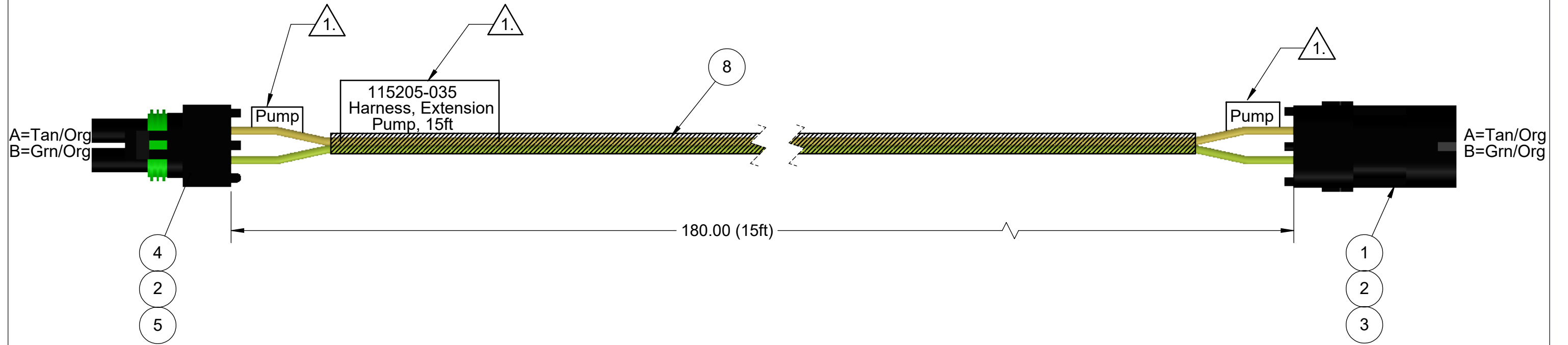

Notes:

1. Label as Required

8	708000-015	Braiding	.159
7	708000-174/3	Wire, 18Ga. Green/Orange	180
6	708000-181/3	Wire, 18Ga. Tan/Orange	180
5	706530-206	Terminal, Female, 16-18Ga.	2
4	706500-502	Tower, 2 Pin	1
3	706530-205	Terminal, Male, 16-18Ga.	2
2	706500-001	Seal, Cable, Green	4
1	706510-502	Shroud, 2 Pin	1
Item	Part Number	Description	Qty



Name	Date	TITLE:
Drawn: BLS	11/30/16	Harness, Extension Pump, 15Ft
Checked:		
QA APP:		
SIZE: B	DWG No: 115205-035	REV: A
SCALE: None		SHEET 1 of 1