

**PROPRIETARY AND CONFIDENTIAL**

THE INFORMATION CONTAINED IN THIS DRAWING IS THE SOLE PROPERTY OF CAPSTAN AG INC. ANY REPRODUCTION IN PART OR AS A WHOLE WITHOUT WRITTEN PERMISSION OF CAPSTAN AG INC IS PROHIBITED

Rev	ECR	Description	Date	By	App
A	1071	Production Release	11/4/15	BLS	

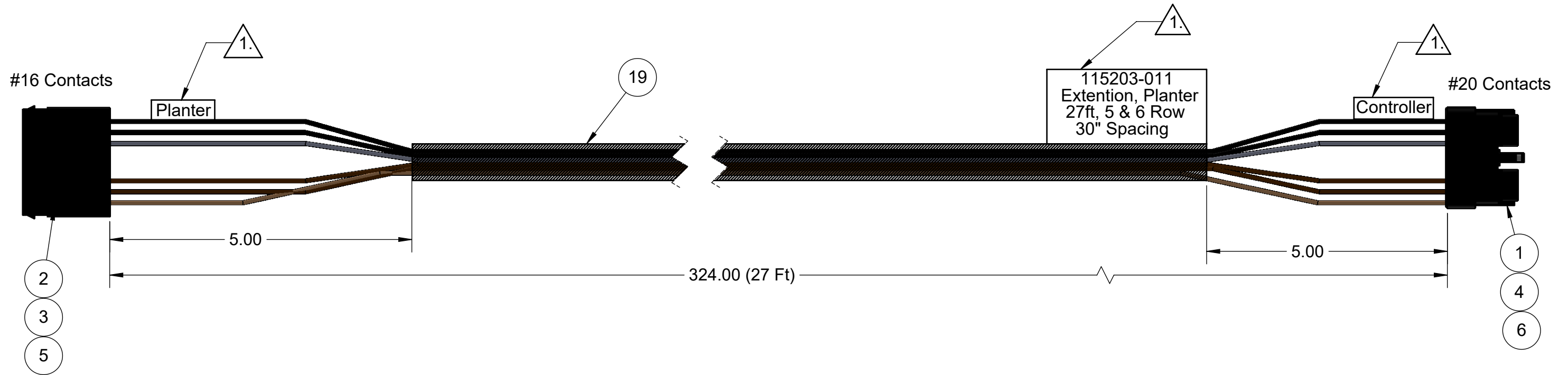

See Page 2 for Connection Diagram

19	708000-015	Braiding	1.5lb
18	708000-174/9	Wire, 18 Ga, Green/White	324
17	708000-182/9	Wire, 18 Ga, Yellow/White	324
16	708000-176/9	Wire, 18 Ga, Red/White	324
15	708000-178/9	Wire, 18 Ga, Blue/White	324
14	708000-179/9	Wire, 18 Ga, Brown/White	324
13	708000-177/9	Wire, 18 Ga, Black/White	324
12	708000-174	Wire, 18 Ga, Green	648
11	708000-182	Wire, 18 Ga, Yellow	648
10	708000-176	Wire, 18 Ga, Red	648
9	708000-178	Wire, 18 Ga, Blue	648
8	708000-179	Wire, 18 Ga, Brown	648
7	708000-177	Wire, 18 Ga, Black	648
6	706530-446	Plug, Cavity, Red, DTM	6
5	706530-346	Plug, Cavity, White, DT	6
4	706530-436	Contact, Socket, 18-20ga. DTM	18
3	706530-335	Contact, Pin, 16-18ga. DT	18
2	706530-298	Rec, 24 Pin, DRC Series Sz 16	1
1	706530-300	Plug, 24 Pin DRC Series Sz 20	1

Item	Part Number	Description	Qty
------	-------------	-------------	-----

**CAPSTAN AG SYSTEMS, INC.**  
 4225 S.W. Kirklawn Ave., Topeka, KS 66609

Notes:

1. Label as Required.

Name	Date	TITLE:
Drawn: BLS	11/4/15	Extension, Planter 27ft, 6 Row
Checked:		
QA APP:		
SIZE: B	DWG No: 115203-011	REV: A
SCALE: None		SHEET 1 of 2

